



ISSN : 2347-2251  
Indo-American Journal of  
Pharma and Bio Sciences



[www.iajpb.com](http://www.iajpb.com)

[iajpb.editor@gmail.com](mailto:iajpb.editor@gmail.com)  
[editor@iajpb.com](mailto:editor@iajpb.com)

<http://www.iajpb.com/currentissue.php>



# A Unified Integrated PHEVs with Interleaved Boost Converter for Power Factor Correction Applications using SRM

1S. Praveen Kumar, 2R. Yedukondalu

## Abstract

This study discusses the rising interest in plug-in hybrid electric vehicles (PHEVs) because of its low carbon emissions, great fuel efficiency, and extended range. This work introduces a PHEV-optimized switching reluctance motor (SRM) powertrain architecture with fewer power electronic components than traditional topologies that has various driving and battery charging capabilities. Depending on the circumstances of the road, four driving modes are possible in motor driving mode. Driving and braking activities may be properly integrated. External battery chargers are not necessary when using one of three charging options. In order to charge the traction battery from the grid, the SRM windings and integrated converter circuit are employed to form a three-channel interleaved boost converter with PFC capabilities. An integrated half-bridge isolation dc/dc converter is utilised to charge the auxiliary battery from the generator or traction battery. A three-phase 12/8 poles SRM is used to test the proposed integrated drive architecture and accompanying control systems.

**Keywords:** Interleaved Boost Converter for PHEVs, PFC, SRM, Battery

## 1. Introduction

EVs, HEVs, and PHEVs (Plug-in Hybrid Electric Vehicles), which emit less carbon pollution and have superior fuel efficiency, are becoming more popular as a result of environmental and economic concerns. [1]-[3]. In order to provide the best of both worlds, PHEVs combine the best features of both standard HEVs and electric cars. Compared to an EV, it offers a longer range and better fuel efficiency. HEVs can only be charged by the internal combustion engine (ICE) generator, which is the only source of power for the battery pack. On the other hand, the PHEV's battery bank may be

recharged from the grid. The PHEV is more acceptable at the present level of battery technology because of its fuelling flexibility [4]-[7].

Because of its high power density and efficiency, the internal permanent magnet synchronous motor (IPMSM) is the most common electric motor for HEVs and PHEVs. [8]. However, NdFeB permanent magnets, which include rare-earth elements, have been highlighted as a serious difficulty in mass manufacture of HEVs [9, 10].

1PG Scholar, 2Associate Professor

1,2Department of EEE, Dr.Samuel George Institute of Engineering and Technology, Markapur, Prakasam, AP, India.

1E-mail: [s.praveen2247@gmail.com](mailto:s.praveen2247@gmail.com), 2E-mail: [santoshpaul717@gmail.com](mailto:santoshpaul717@gmail.com)

This article can be downloaded from  
<http://www.iajpb.com/currentissue.php>

For its robust construction, strong starting torque, broad speed range, inherent fault-tolerance, and high operating efficiency (SRM), the rare-earth-free motor (SRM) is very competitive in transportation applications [11–13]. Because of the PHEVs' limited inside space, increasing the power density of the motors is insufficient in certain situations. Integrated electric drivetrains with battery charge capacity that reuse the traction motor and power electronics must have a well-designed power converter for the electric drive system. A PHEV onboard charger (OBC) has been tested using induction motors, permanent magnet synchronous motors, and SRMs. The motors for An external power rectifier and LC filter are used to turn the tractionstator windings and power converter into a boost battery charger. One of the issues with incorporating the SRM into a PHEV programme is the need for a specialised power converter. An improved power converter for plug-in hybrid vehicles (PHEV) with a reduced power unit is discussed in this article. Depending on the road conditions, the SRM may be powered solely by the traction battery, alone by the generator, or

both combined in motor operating modes. Driving and braking activities may be efficiently carried out using the proposed topology. For charging the traction battery, the rectifier, SRM windings, and power converter create an interleaved three-channel boost power factor correction (PFC) converter. If you need inductors for your OBC, you don't need to make any changes to your SRM. For the suggested integrated converter architecture to work, it makes use of the stator windings and an optimised power converter for SRM, as well as an optimal power converter for auxiliary battery charging (T2A). Numerous components in this converter have multiple purposes for various modes of operation. These include the rectifier, the SRM winding and its power converter, and the capacitors C1 and C2. The suggested integrated powertrain offers more working modes and better integration speeds than the current architectures. The electric drive system might also be lowered in cost and bulk, enabling SRM to be used in PHEVs. Control solutions for driving and charging modes are also given to perform the respective duties.

## 2. Integrated SRM Powertrain Topology for PHEV

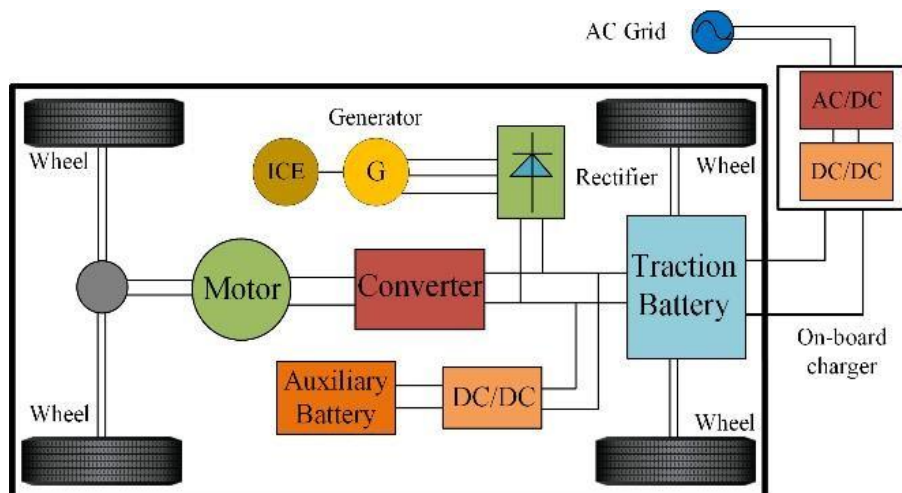

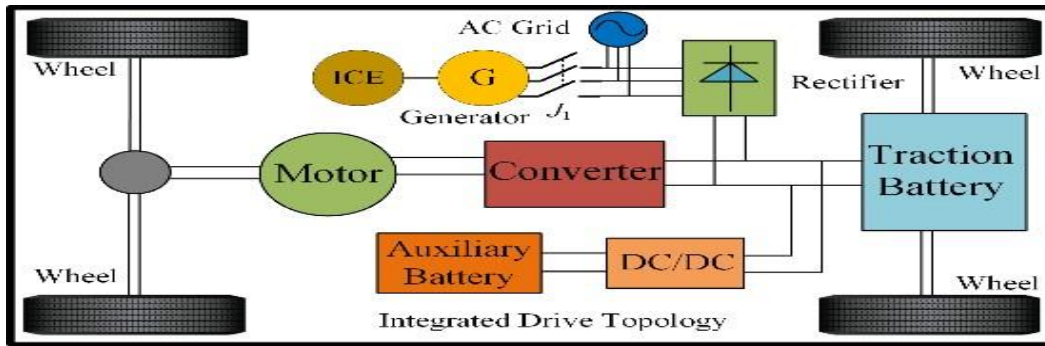
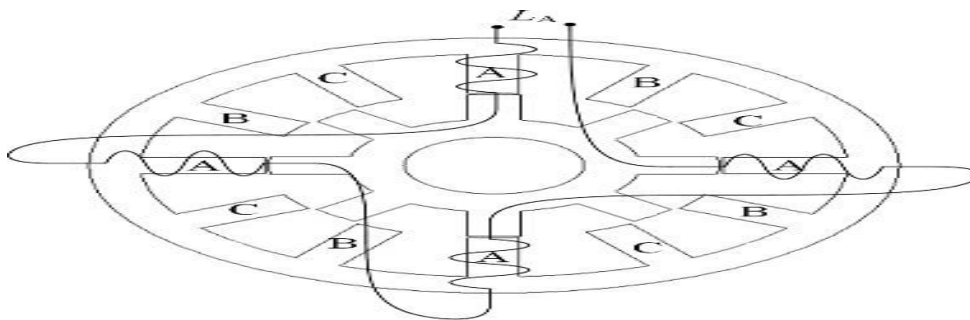

**Figure. 1 Schematic of the PHEV powertrain. (a) Traditional powertrain. (b) Proposed powertrain.**

Figure. 1 shows a schematic of a PHEV's drivetrain. Figure 1(a) shows a typical conventional electrified powertrain, which includes an ICE, a generator powered by the ICE, a rectifier for rectifying, a major energy storage source, i.e., a traction battery bank for propulsion, and a traction motor for propulsion. an independent dc/dc converter, a main converter, and an auxiliary battery for automotive electronics are all coupled to a mechanical driveline and an auxiliary battery for automotive electronics. The traction battery is normally charged using an OBC that includes an

ac/dc converter, a dc/dc converter, as well as several inductors and capacitors.

Figure 1(b) shows an integrated drive architecture that is recommended to promote integration. The OBC is no longer available as a stand-alone product. Motor windings serve as filter inductors for the generator and motor's current power converters, which in turn serve as filters for the converters going to the onboard computer (OBC). A relay J1 is provided to allow the generator to be connected or disconnected from the rectifier.



Phase A of a three-phase 12/8 poles SRM is seen in Figure 2a, with the windings on four poles connected in series. The phase A winding is denoted by the LA in Figure 2(a). There are identical winding connections for phases B and C. Schematic diagram of suggested integrated SRM drive architecture is shown in Figure 2(b) (b). Three-phase AC electricity is generated by the ICE, which mechanically connects to the

generator. A diode-bridge rectifier is used after the generator to convert ac power to dc power. As long as the ICE and generator aren't running, a grid adaptor can power the battery bank. Before the rectifier, an EMI filter is used to eliminate battery-side electromagnetic interference noise transmission. A relay J1 is used to disconnect the generator from the grid while charging the traction battery.

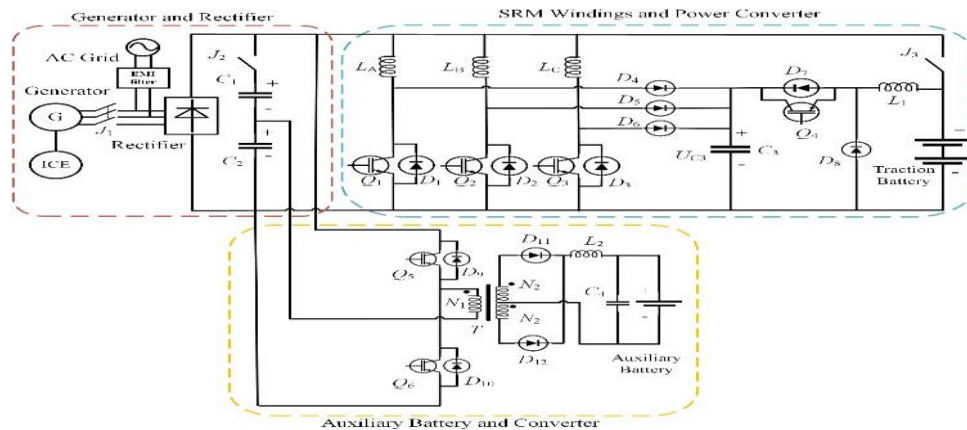

Figure. 2 Diagram of the SRM drive converter for PHEV. (a) Structure of the SRM. (b) Detailed diagram of the proposed integrated converter.

There are three phases in SRM's three-phase windings. A total of ten diodes D1–D8, an inductor L1, and a capacitor C3 comprise the SRM's power converter. Constructed from IGBTs Q5 and Q6, transistor T, capacitor C4, and inductor L2, the half-bridge isolation dc/dc converter charges the auxiliary battery. As part of the half-bridge isolation dc/dc converter for charging the auxiliary battery, the bus capacitors C1 and C2 are connected in series. The traction battery powers the propulsion engine, while the auxiliary battery powers the onboard electronics. The relays J2 and J3 are utilised to perform a variety of functions. PHEV Modes of Operation

It is possible to operate the PHEV exclusively on traction battery power, solely on generator power or both while in driving mode, and this

relay J2 is switched on. Winding excitation, winding demagnetization, and demagnetization energy recovery states exist for the aforementioned three modes.

Powered only by a Traction Battery  
Generator-Only Powered

Traction Battery and Generator Cooperatively Operate

#### PHEV Battery-Charging Modes

☐ An integrated battery charger is no longer required because of the anticipated improved drive architecture. Generator or grid charging of the battery banks may be ordered by the driver. G2T, G2A, and T2A battery charging modes will all be supported by the integrated topology.

☐ Traction Battery Charged by Grid (G2T)

☐ Auxiliary Battery Charged by Generator (G2A)

☐ Auxiliary Battery Charged by Traction Battery (T2A)

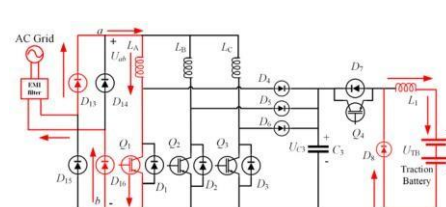
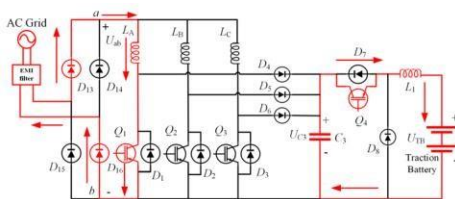

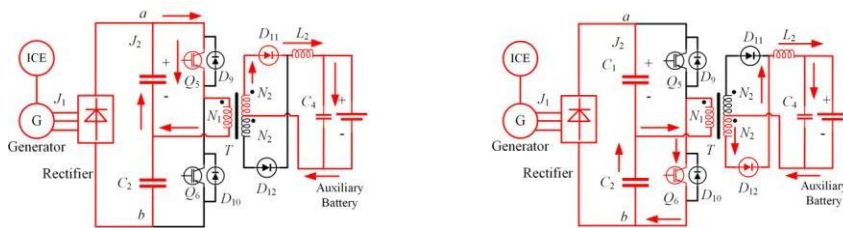
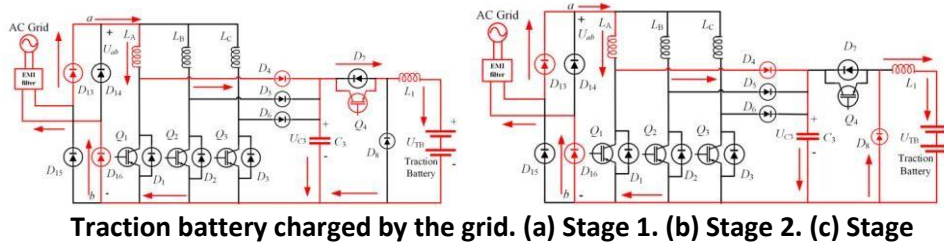

Auxiliary battery charged by the generator. (a) Stage 1. (b) Stage 2.

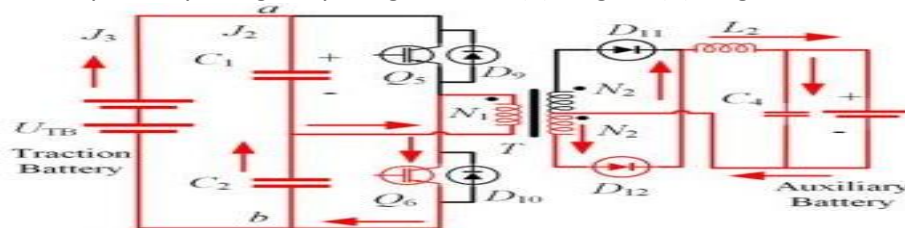

### 3. Control Schemes for Motoring and Charging Modes

#### PHEV Driving Control Strategy

Figure. 10 displays a block diagram of the control strategy in driving mode. Because of its simple configuration and high robustness, the current hysteresis controller is used for phase current closed-loop operation. The current hysteresis bandwidth is 2 A, and the sampling frequency is 13 kHz. The error between the specified current value  $I$  and the real current values  $i_A$ ,  $i_B$ , and  $i_C$  is used as the input.

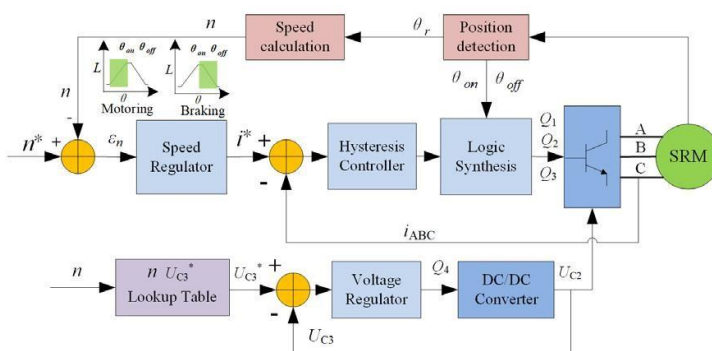

Figure. 10 Diagram of the driving control strategy.

Switching signals Q1, Q2, and Q3 are generated by synthesising the ON, OFF, and hysteresis signals. It is utilised for closed-loop control of the rotor speed using a PI regulator and the input to the PI regulator is the difference between the stated speed and the actual speed.

n. The output of the internal current regulator is the provided value of current  $I$ . When the speed is less than the basic speed of 1000 r/min, the UC3 is set to 72 V. In general, the amount of time it takes to demagnetize a piece of metal as the rotating speed rises increases as well. The UC3 voltage rises linearly from 1000 to 2000 r/min as the rotation speed

is raised, until it reaches 108 V. A PI regulator is used to regulate the UC3 voltage in closed loop.

#### Battery Charging Control Strategy

Fig. 11 shows the G2T mode's control block diagrams in action. The controller for the interleaved boost converter consists of two closed-loops as shown in Fig. 11 (a). A PI regulator is used to regulate the voltage UC3 of the capacitor C3 and output the amplitude of the current inner loop reference value  $I^*$ . By using the phase-locked loop (PLL) and the cos and absolute value (ABS) modules, the instantaneous current reference value  $I^*_{ref}$  is calculated.

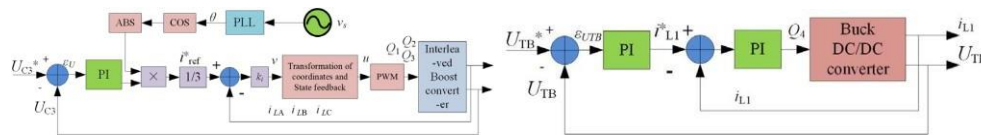

Block diagrams of the control system for G2T mode. (a) Interleaved boost converter. (b) Buck converter.

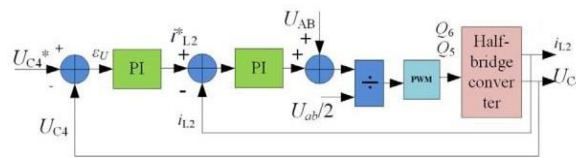

Block diagrams of the control system for G2A and T2A modes.

#### 4. Simulation Results

TABLE I  
SRM DRIVE SYSTEM SPECIFICATION

Specifications	Value
Phase number	3
Stator/rotor poles	12/8
Rated power (W)	750
Rated speed (r/min)	1000
Minimum phase inductance (mH)	0.3
Maximum phase inductance (mH)	1.6

Table I lists the SRM drive system specs, and MATLAB/Simulink software is used to simulate

it. The suggested integrated SRM drive architecture and control techniques are tested in a three-phase,

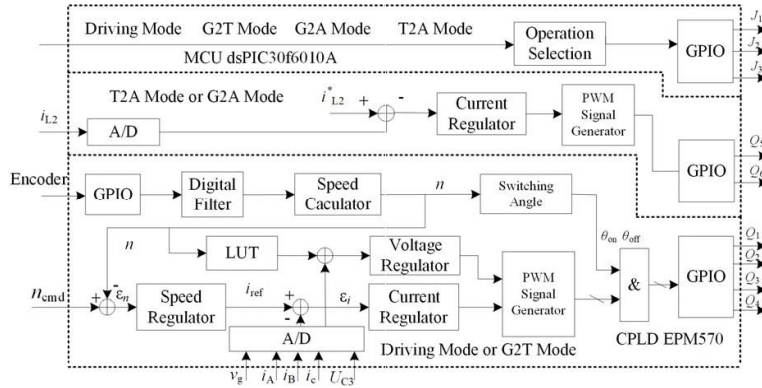

12/8-pole SRM simulation. Figure 13 shows the controller's schematic.

**Figure. 13. Schematic of the controller.**

As shown in Figure 14,  $i_A$  represents phase A phase current,  $i_G$  represents generator output current,  $i_{TB}$  represents traction battery current, and  $U_{C3}$  indicates capacitor C3 voltage at 500r/min. This is shown in Figure 14 by a battery-driven SRM with no use of the generator in battery driving mode.

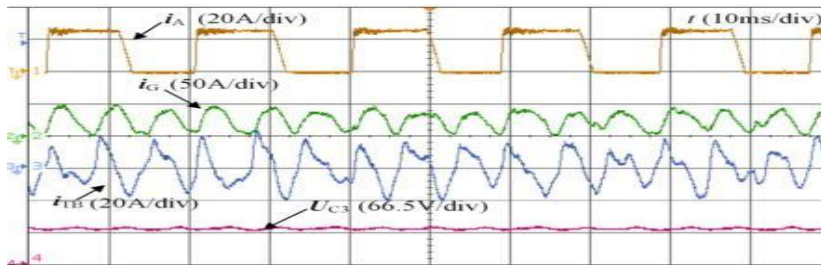
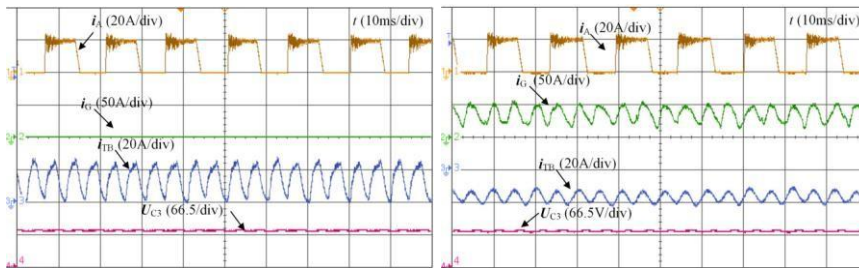

## 5. Conclusion

An efficient SRM drive converter architecture for PHEVs has been presented in this research, which can handle a variety of driving and charging operations without the need for external components. The following are the article's major contributions: an integrated power converter architecture with fewer circuit components, such as power semiconductor modules, inductors, and capacitors, is suggested

instead of the standard electrified powertrain for PHEVs. Only three relays are needed to accomplish a wide range of driving and charging modes. Regenerative braking, battery driving, engine driving, and generator and traction battery hybrid operating modes are all available in the drive mode depending on the load circumstances. The suggested electric drive technology works better in high-speed service.

This article can be downloaded from  
<http://www.iajpb.com/currentissue.php>



An interleaved boost PFC converter is formed in charging mode using three channels of rectifier and SRM windings, which helps reduce input current ripple and enhance charging power efficiency. The PHEV has three charging modes: G2T, G2A, and T2A, all of which improve charging flexibility. There are many purposes for many sections of the integrated converter, including the rectifier, SRM windings and power converter, as well as capacitors C1 and C2. Electric drive systems are more integrated and cost and volume are lowered as a consequence of these changes. Furthermore, simulations are utilised to verify the suggested controllers for motor driving, adjustable power management, as well as battery charging.

#### References

Modern Electric, Hybrid Electric, and Fuel Cell Vehicles: Fundamentals, Theory, and Design, by M. Ehsani, Y. Gao, and A. Emadi. CRC Press, New York, NY, USA, 2010.

2] A. Khaligh and Z. Li, "Battery, ultracapacitor, fuel cell, and hybrid energy storage systems: State of the art," IEEE Trans. Veh. Technol., vol. 59, no. 6, pp 2806–2814, Jul. 2010. [3] [4]

"Review of battery charger topologies, charging power levels, and infrastructure for plug-in electric and hybrid cars" by M. Yilmaz and P. T. Krein, IEEE Trans. Power Electron., Vol. 28, No. 5, May 2013.

Charging strategies for plug-in hybrid electric cars in the smart grid: A study, P.-Y. Kong and G. K Karagiannidis, IEEE Access, vol.4, 2016, pp.6846–6875.

For example, in the IEEE Trans. Veh. Technol. 66, no. 6, pp. 4534–4549 (June 2017), the authors of a paper titled "Energy Management in Plug-in Hybrid Electric Vehicles: Recent Progress and a Connected Vehicles Perspective" discuss recent progress in the area of energy management in plug-in hybrid electric vehicles.

In "Aggregation and bidirectional charging power regulation of plug-in hybrid electric vehicles: Generation system adequacy study," by Z. Liu, D. Wang, H. Jia, N. Djilali, and W. Zhang, IEEE Transactions on Sustainability and Energy, 6, no. 2, April 2015, pp. 325–335.

H. Fathabadi, "Plug-in hybrid electric vehicles: Using clean and renewable energy-based auxiliary power sources to replace internal combustion engines," IEEE Trans. Power Electron., vol. 33, no. 11, pp. 9611–9618, Nov. 2018.

For electric, hybrid-electric and plug-in hybrid electric cars, "power electronics and motor drives" are the subject of a paper published in IEEE Transactions on Industrial Electronics in June 2008, pp. 2237–2245.

Comparative evaluation of internal permanent magnet (IPM), induction, and switching reluctance motor drives for EV and HEV applications," IEEE Trans. Transport. Electrific., vol. 1, no. 3, pp. 245–254, October 15, 2015.

Comparing electric motors: An analysis based on four common driving schedules," IEEE Industrial and Applied Mathematics Magazine, July 2014, pp. 12–20, by Kiyota, Sugimoto and Chiba (Kiyota, Sugimoto, and Chiba).

"Advantages of switching reluctance motor applications to electric and hybrid vehicles: Design and control challenges," IEEE Trans. Ind. Appl, vol. 36, no. 1, pp. 111–121, Jan./Feb. 2000, K. M. Rahman, B Fahimi, G. Suresh, A V. Rajarathnam and M. Ehsani.

Test findings and torque enhancement of the 50-kW switching reluctance motor built for hybrid electric cars by M. Takeno and colleagues in IEEE Transactions on Industrial Applications, vol. 48, no. 4, July 2012, pp. 1327–1334.

It's been reported that the development of a rare-earth-free SR motor with a high torque density for hybrid automobiles has been completed by the researchers in this study.